

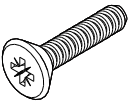

REVIVE BED - WITHOUT SLATS ASSEMBLY INSTRUCTIONS FOR BED INSTALLATION

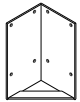

HARDWARE ENCLOSED

 <p>SCREW M6x25 (32pcs)</p>	 <p>METAL BRACKET (4pcs)</p>	 <p>L BRACKET (6pcs)</p>	 <p>SHORT LEG (1pc)</p>	 <p>LONG LEG (1pc)</p>
--	---	---	--	--

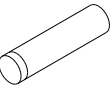
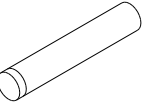
TOOL REQUIRED

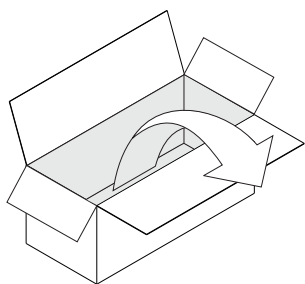
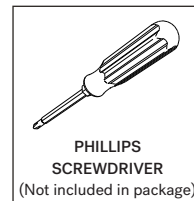

IN YOUR PACKAGE :

ASSEMBLY INSTRUCTIONS
HARDWARE (AS LISTED ABOVE)

PARTS TO BE INSTALLED

1. HEADBOARD (1 pc)
2. SIDE RAILS (2 pcs)
3. FOOTBOARD (1 pc)
4. CENTRAL SUPPORT (1 pc)

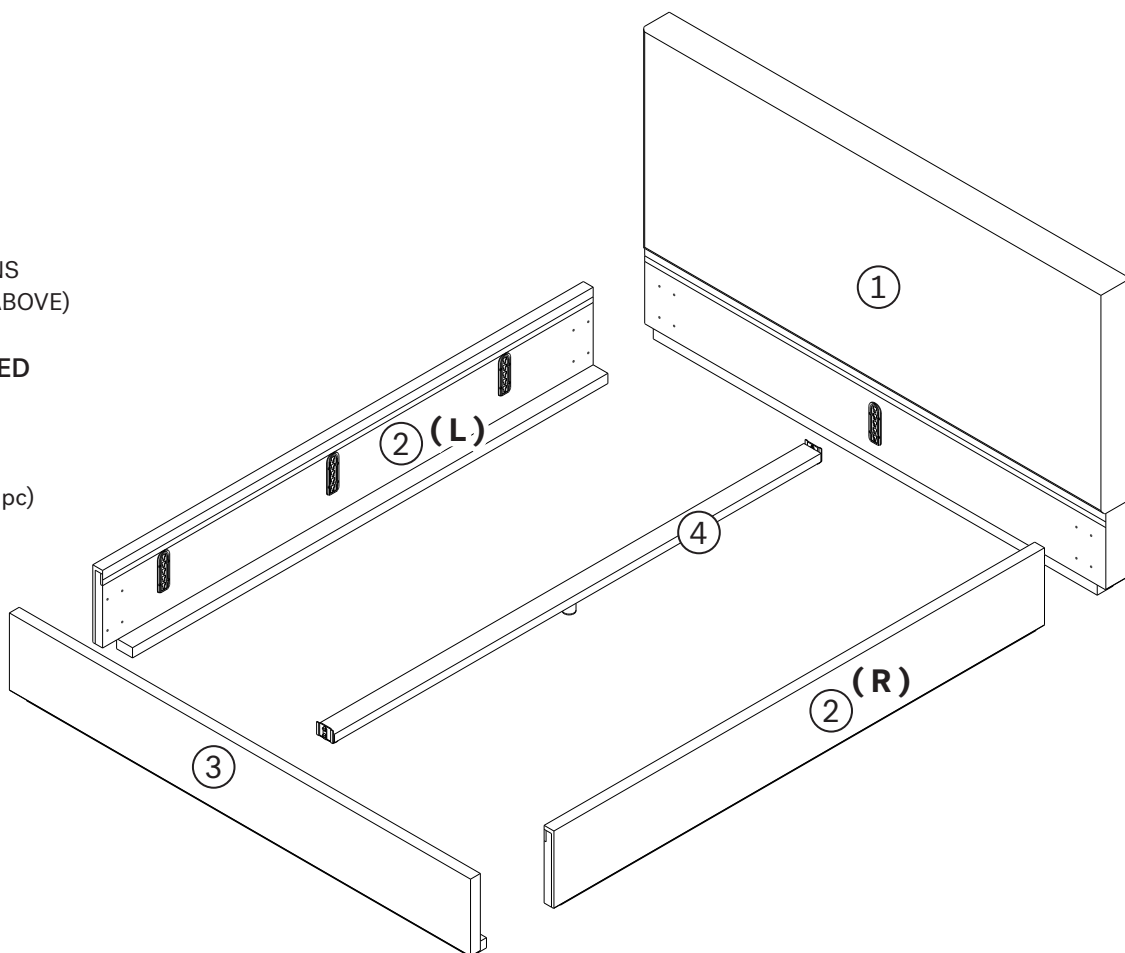

SYMBOLS



DIRECTION

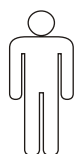

NUMBER OF
PERSONS NEEDED



USE HAND



USE PHILLIPS SCREWDRIVER
TO TIGHTEN

NOTICE

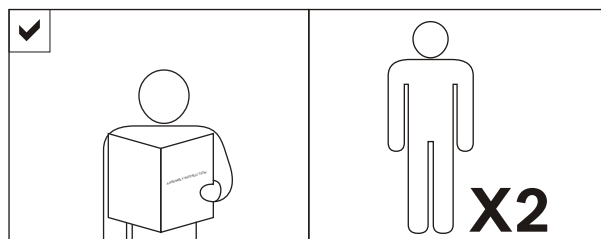

REVIVE BED - WITHOUT SLATS
ASSEMBLY INSTRUCTIONS FOR BED INSTALLATION



A INSTALLING METAL BRACKETS TO BOTH SIDE RAILS

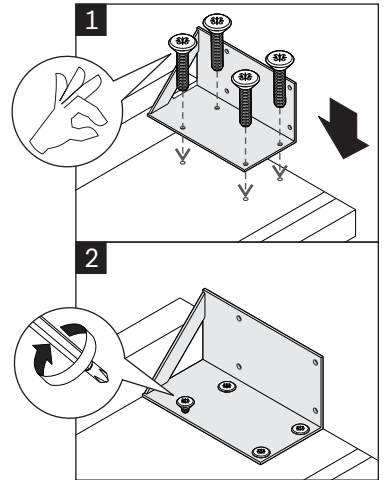
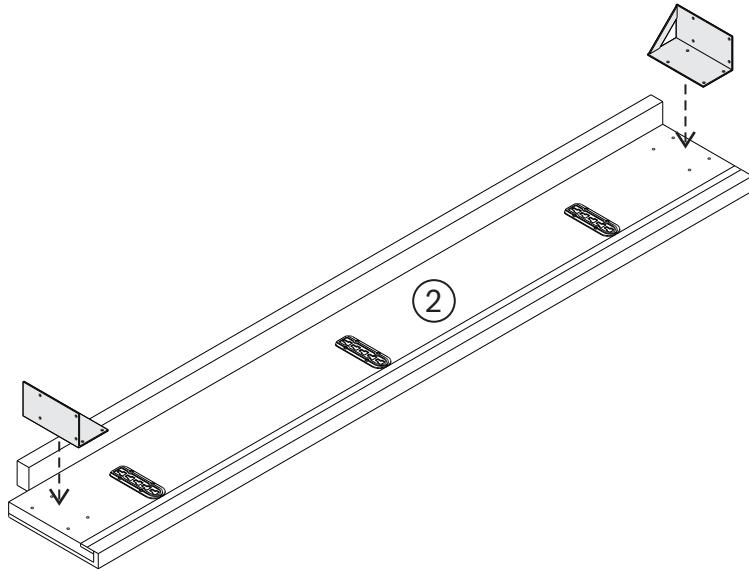

- USE METAL BRACKETS (4X)
- USE SCREWS M6x25 (16X)
- DO NOT TIGHTEN FULLY

B ATTACHING SIDE RAILS TO FOOTBOARD

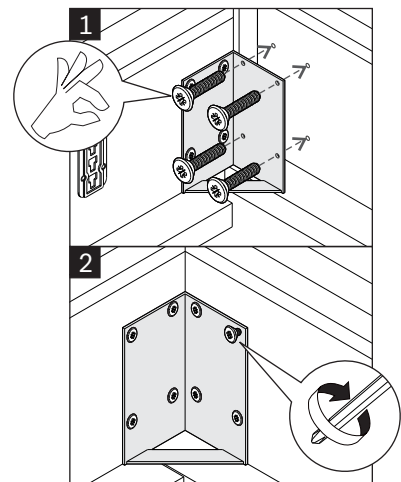
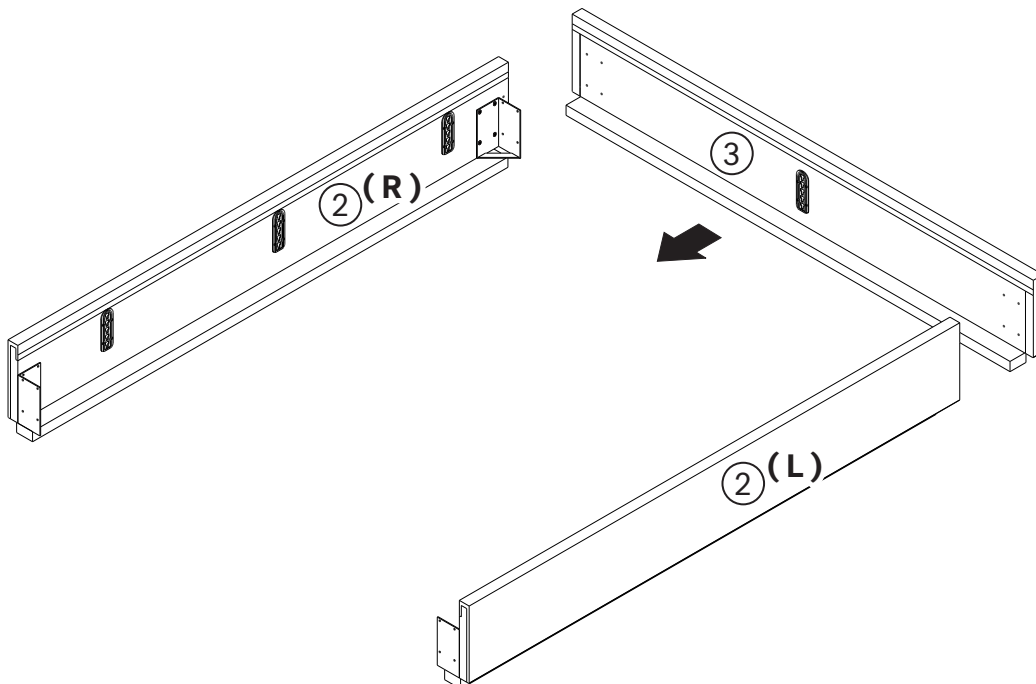

- USE SCREWS M6x25 (8X)
- DO NOT TIGHTEN FULLY

REVIVE BED - WITHOUT SLATS
ASSEMBLY INSTRUCTIONS FOR BED INSTALLATION



C ATTACHING SIDE RAILS TO HEADBOARD

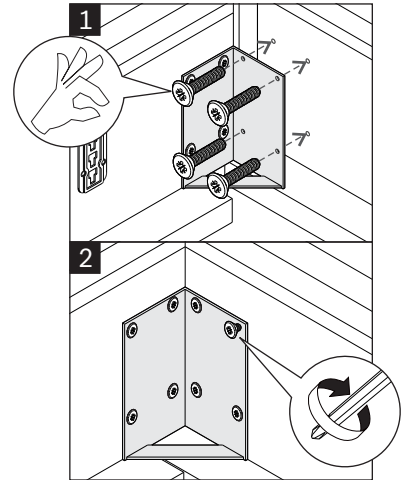
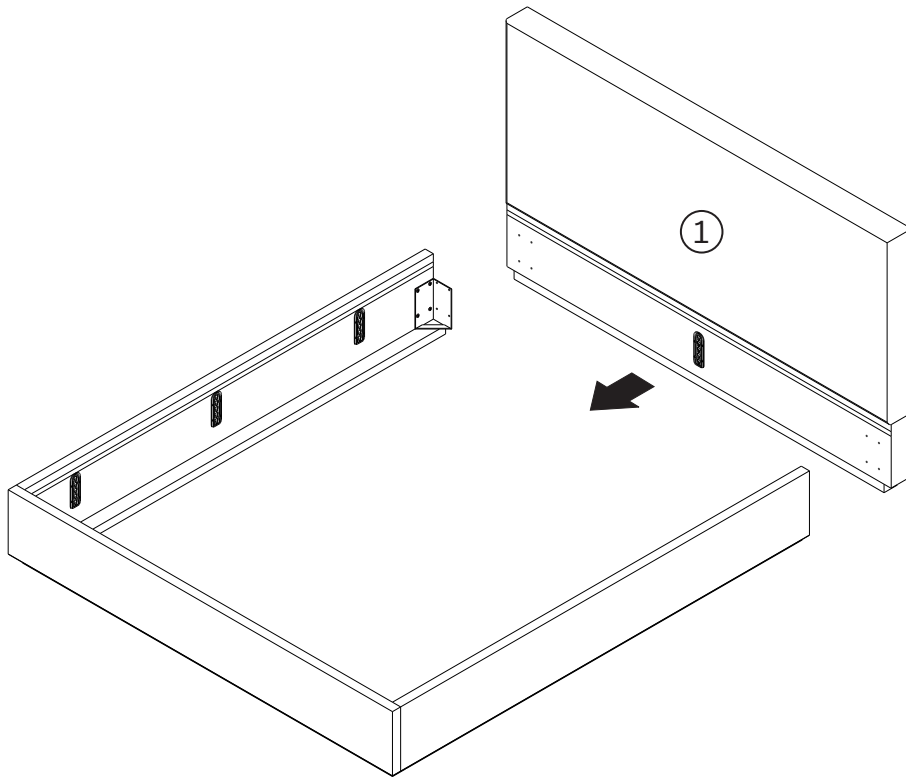

-  - USE SCREWS M6x25 (8X)
-  - DO NOT TIGHTEN FULLY

D ATTACHING LEG TO CENTRAL SUPPORT

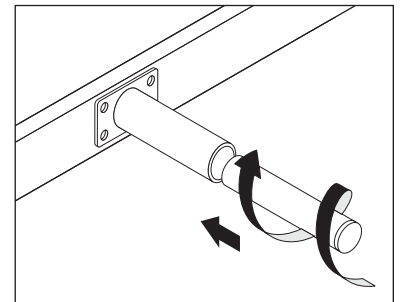
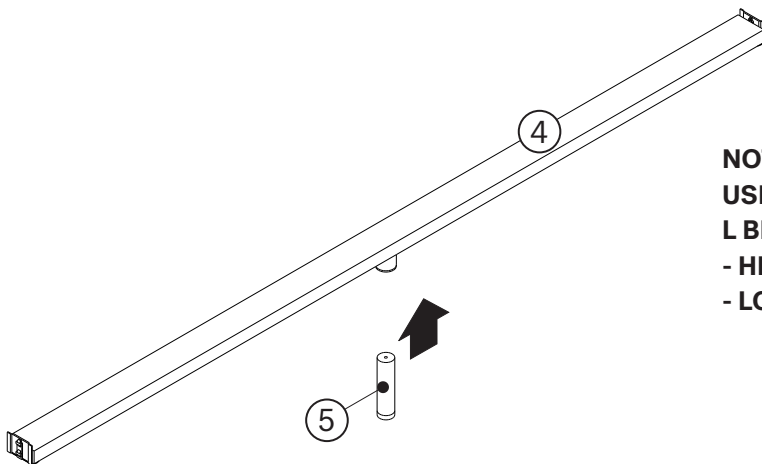

- NOTE :**
- USE SHORT OR LONG LEG DEPENDING ON DESIRED L BRACKET HEIGHT - SEE STEP F FOR MORE DETAIL
 - HIGHEST L BRACKET LEVEL : LONG LEG
 - LOWEST L BRACKET LEVEL : SHORT LEG

REVIVE BED - WITHOUT SLATS ASSEMBLY INSTRUCTIONS FOR BED INSTALLATION



E ATTACHING CENTRAL SUPPORT

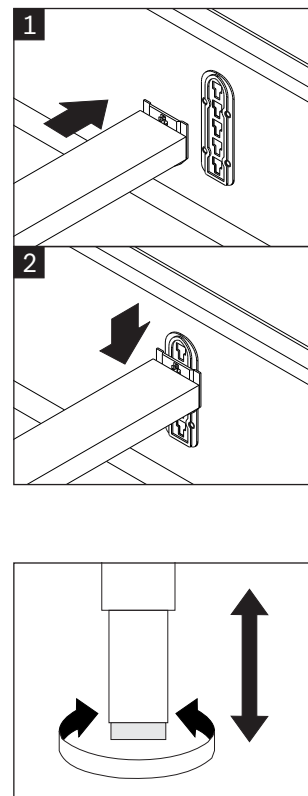
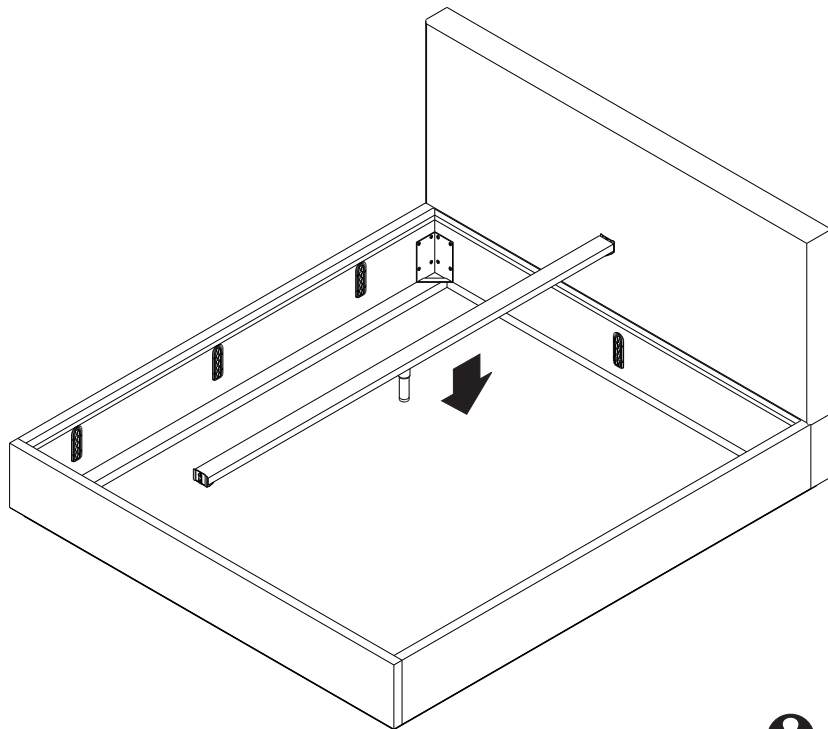

! TAKE EXTRA CARE TO ENSURE CENTRAL LEG IS IN CONTACT WITH THE FLOOR

F ATTACHING L BRACKETS

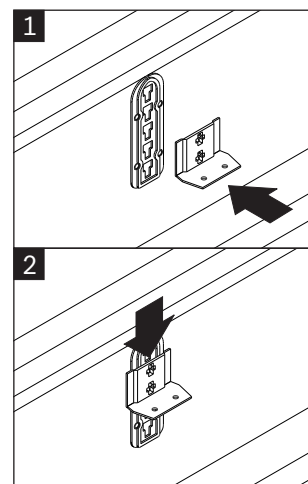
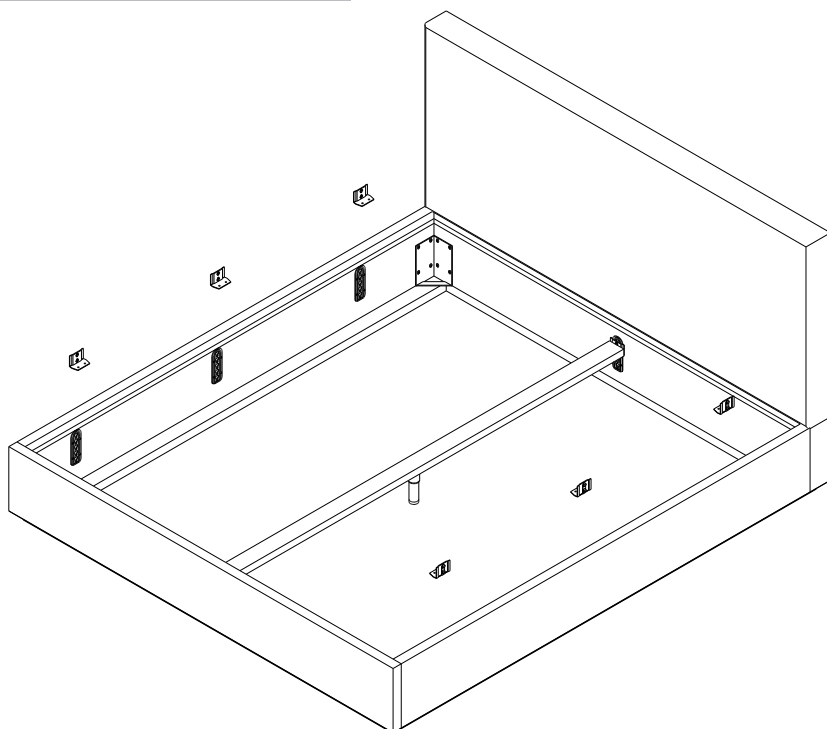

! ENSURE ALL L BRACKET LEVELS ALIGN WITH CHOSEN CENTRAL LEG HEIGHT

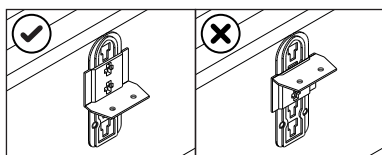

REVIVE BED - WITHOUT SLATS ASSEMBLY INSTRUCTIONS FOR BED INSTALLATION



G ADJUST ALL SCREWS TO TIGHTEN

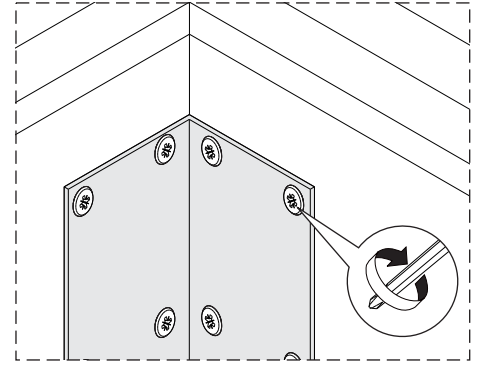

! TIGHTEN FULLY FOR ALL SCREWS

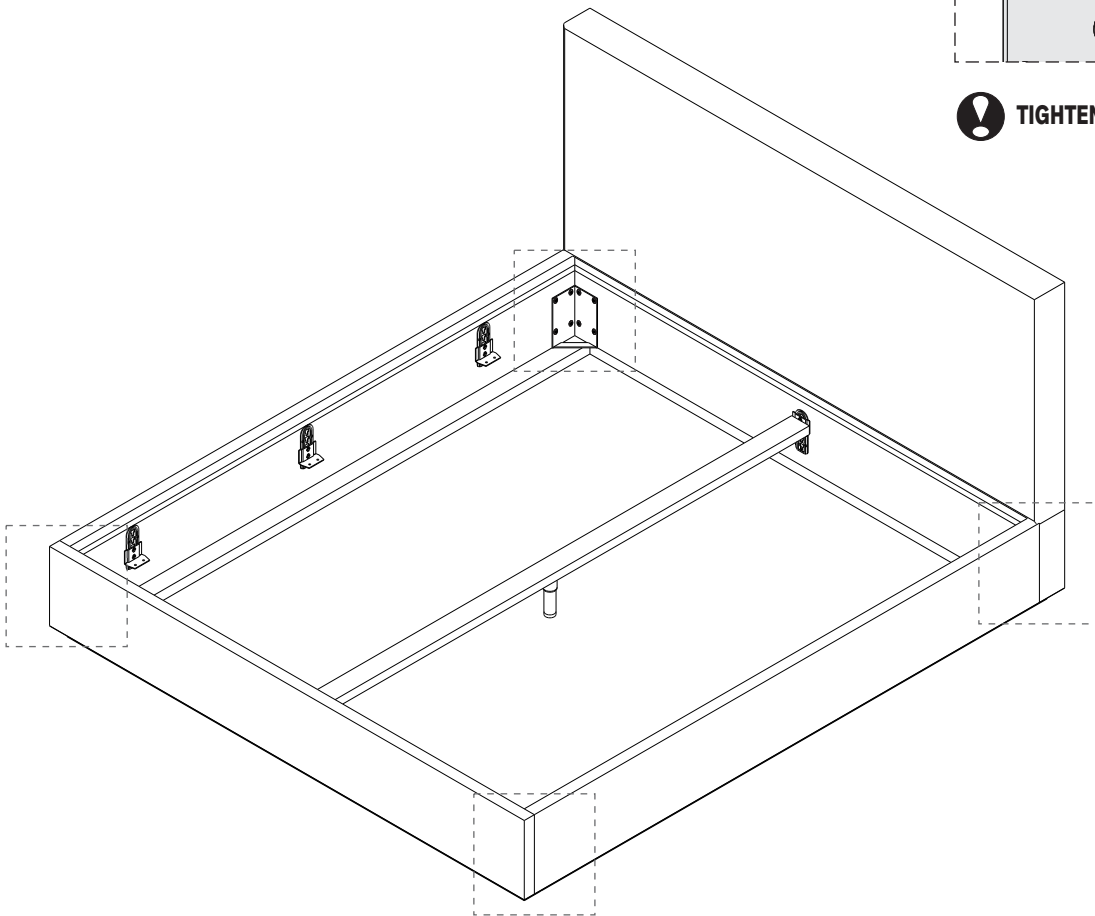

! FRAME IS NOW READY TO FIT REMOVABLE FABRIC COVER
AND PLACE MATTRESS

